

MATERIAL SPECIFICATION				
UNDERSTRUCTURE	CONTAINER	TAILGATE	HINGES	LATCH
FLOOR 7GA HI TENSILE	8" CHANNEL 12GA	SKIN 12GA HI TENSILE	A36 STEEL	A36 STEEL
LONGSILLS 3/16 2x6 TUBING	WALLS 12GA HI TENSILE	4 1/4 CHANNEL	STAINLESS PINS	
CROSSMEMBERS 3" 4.1# CHANNEL	TARP BAR 3/4 PIPE			

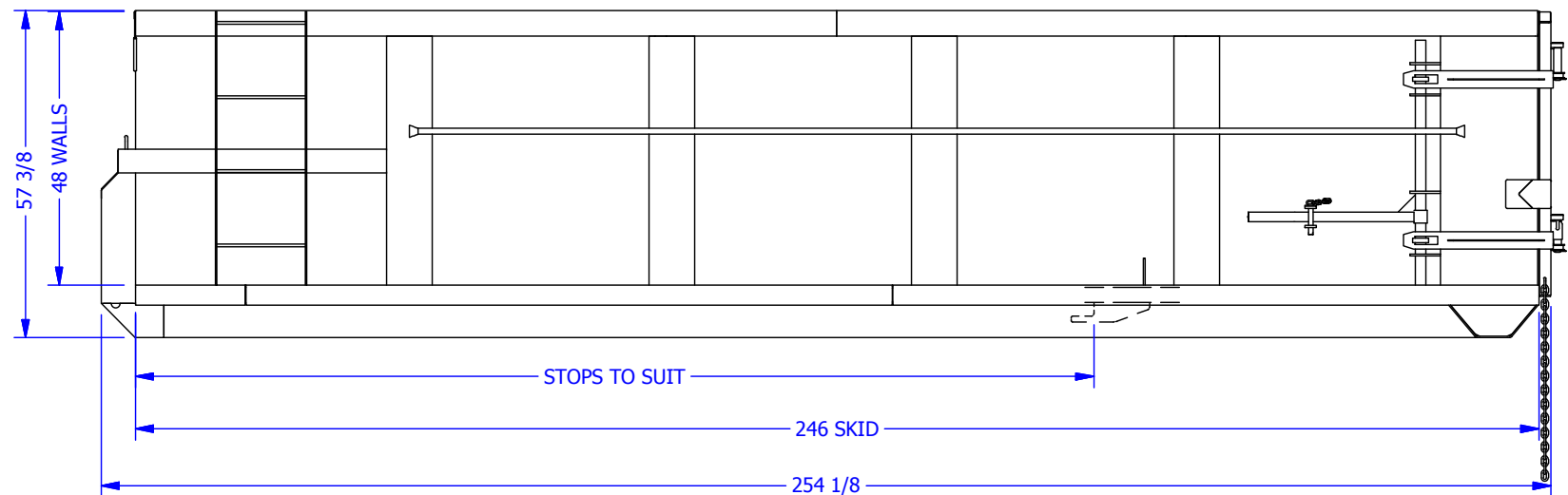
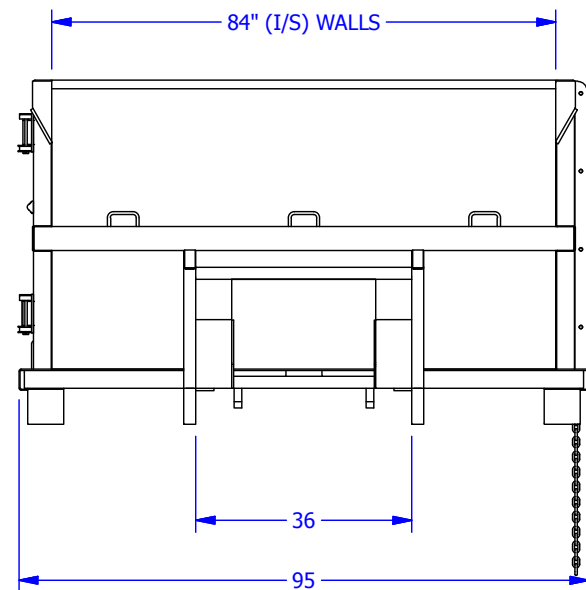

THIS DRAWING IS THE SOLE PROPERTY OF UNIVERSAL HANDLING EQUIPMENT COMPANY LIMITED. REPRODUCTION IN WHOLE OR IN PART IS STRICTLY PROHIBITED WITHOUT OUR WRITTEN CONSENT

UNLESS OTHERWISE SPECIFIED DIMENSIONS ARE IN INCHES AND TOLERANCES ARE:
 FRAC .XXX ANGLE
 ± 1/32 ± .005 ± 1/2'

REV	DESCRIPTION	DATE	BY



UNIVERSAL HANDLING EQUIPMENT

20 YD CORO, 246" X 84" X 48", CABLE SKID, STOPS@168, SWING LATCH			Sheet 1 of 1	
DESIGN: TWW	09/08/2006	DWG. NO.	REV	
DWG: DRM	28/05/2013	SCALE: 1/25	CORO-G0014	0