

THIS DRAWING IS THE SOLE PROPERTY OF
UNIVERSAL HANDLING EQUIPMENT CO. LTD.
REPRODUCTION IN WHOLE OR IN PART IS
STRICTLY PROHIBITED WITHOUT OUR
WRITTEN CONSENT.

ALL PROPOSAL DRAWINGS
SUBJECT TO CHANGE
WITHOUT NOTICE

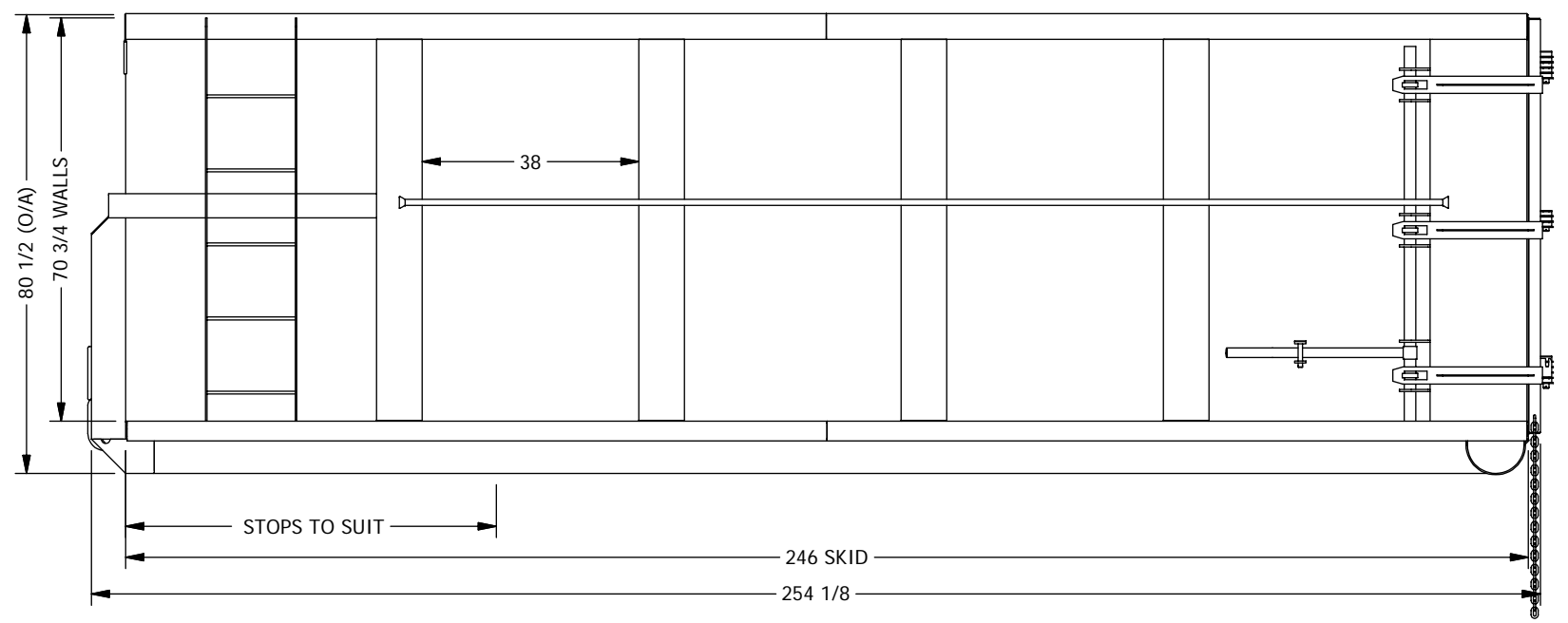
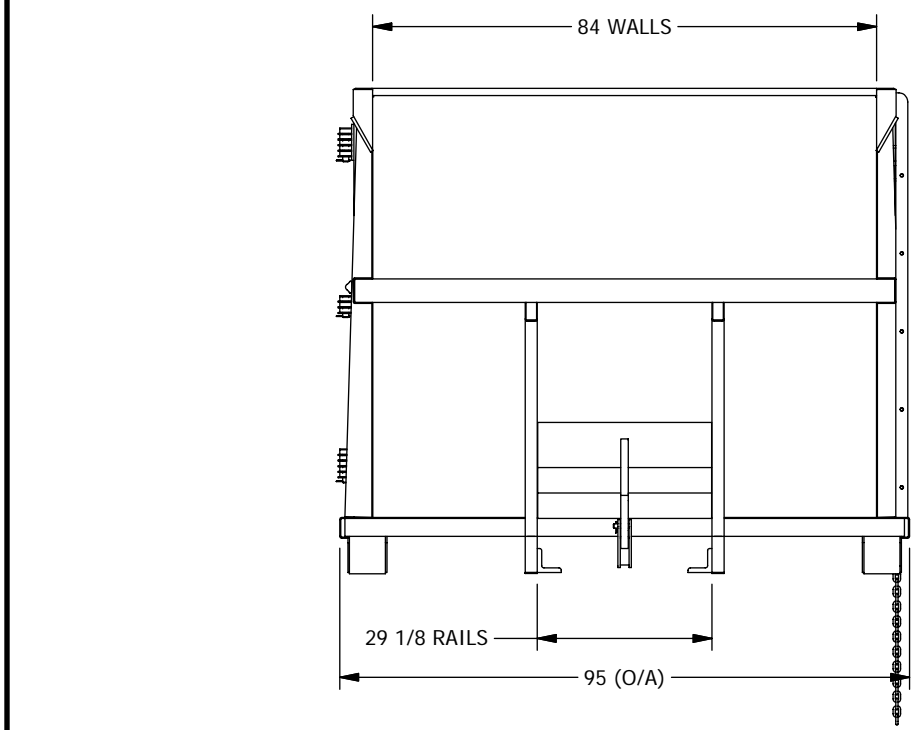
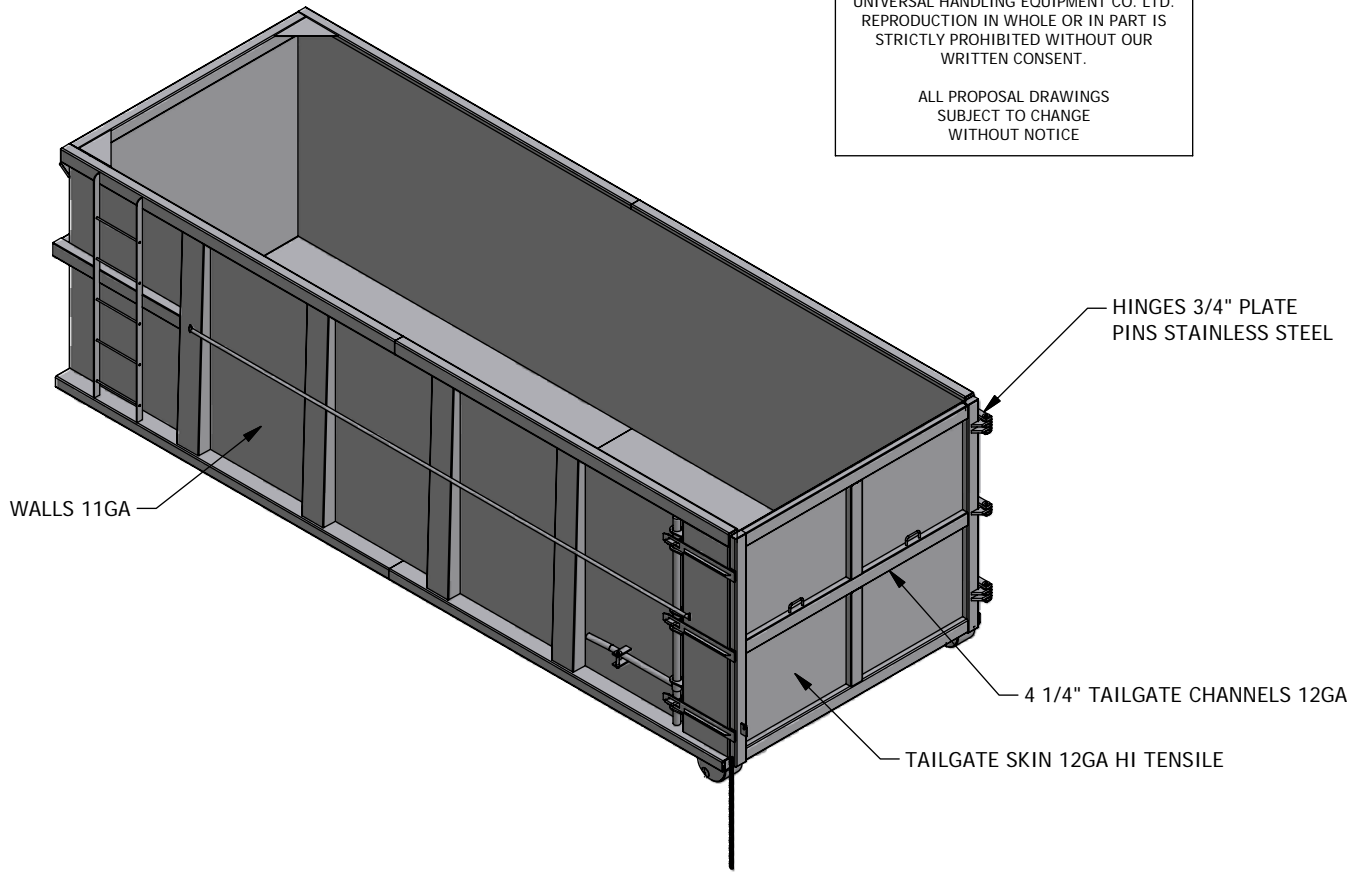
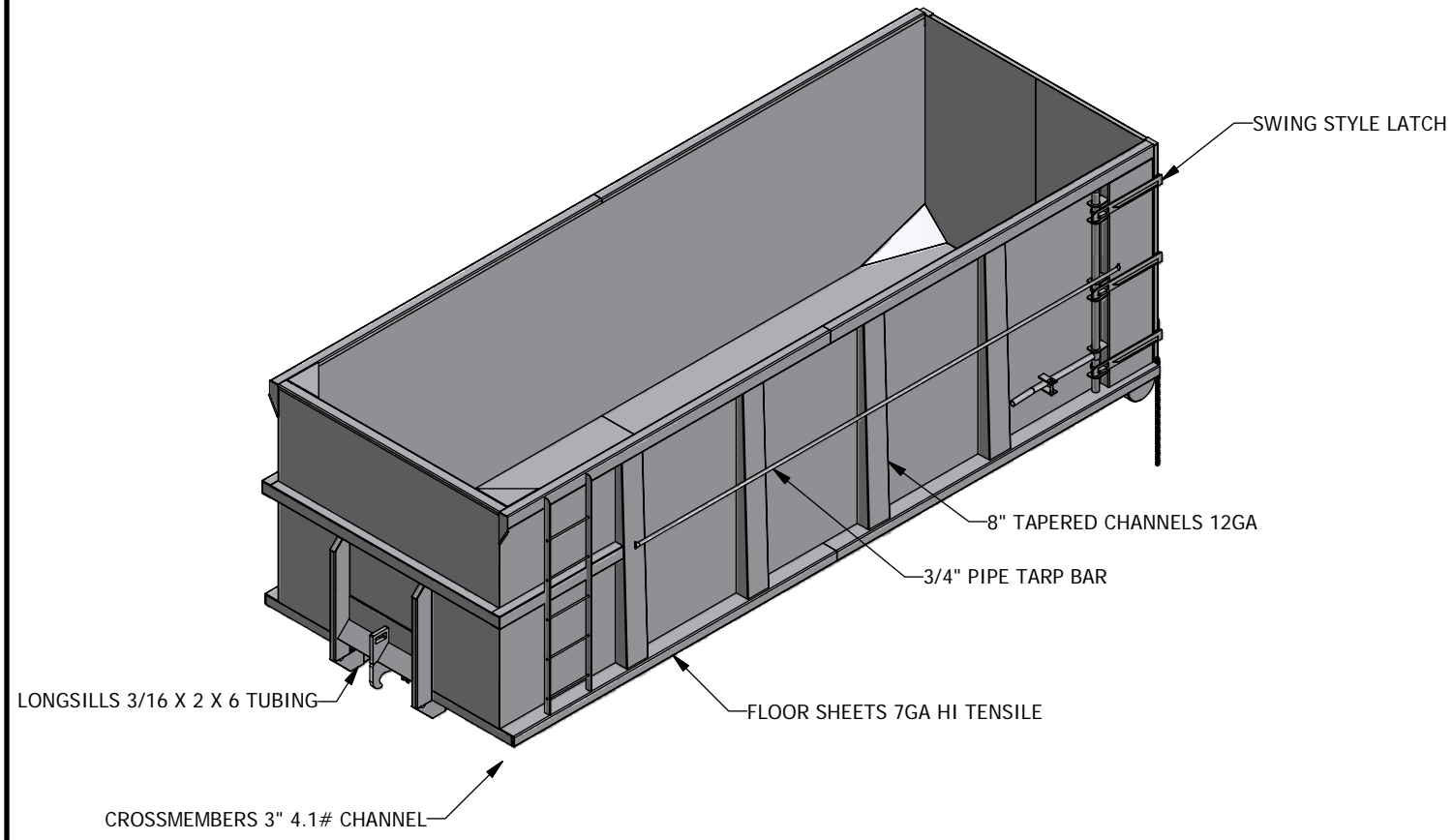

THIS DRAWING IS THE SOLE
PROPERTY OF UNIVERSAL HANDLING
EQUIPMENT COMPANY LIMITED.
REPRODUCTION IN WHOLE OR IN
PART IS STRICTLY PROHIBITED
WITHOUT OUR WRITTEN CONSENT

UNLESS OTHERWISE
SPECIFIED DIMENSIONS
ARE IN INCHES
AND TOLERANCES ARE:

FRAC	.XXX	ANGLE
± 1/32	± .002	± 1/2°

REV	DESCRIPTION	DATE	BY



UNIVERSAL HANDLING EQUIPMENT

30 YD CORO, 246" X 84" X 70 3/4", BAIL SKID, SWING LATCH

Sheet 1 of 1

DESIGN: TWW	2/16/2007	DWG. NO.	REV
DWG: TWW	2/16/2007	CORO-G0061	0
SCALE: 1/32			